

## Features and Benefits

- AEC-Q100 automotive qualified
- BiCMOS Technology
- Magnetic Type: Latch
- With Internal Pull Up Resistor
- Wide Operating Voltage Range:  
Supply Voltage 2.8~24V
- Specified Operating Temperature Range:  
From -40 ~150
- High Magnetic Sensitivity  
 $B_{OP}=24\text{Gauss}$ ,  $B_{RP}=-24\text{Gauss}$  (typical)
- Reversed Power Supply Protection
- Output Limiting-Current Protection
- RoHS Compliant  
2011/65/EU

## Applications

- Automotive, Home appliances, Industrial
- DC Fan, Electric tools
- Magnetic Encoder
- Flow Sensor

## Family Members

Part number	Description
MT3411A-EN	Flat TO-92 package, bulk packaging (1000pcs/bag)
MT3411A-T-EN	Flat TO-92 package, radial lead, bulk packaging (1000pcs/bag)
MT3411AT-EN	SOT-23 package, tape and reel packaging (3000pcs/bag)
MT3411AT-N-EN*	SOT-23 package, invert output, tape and reel packaging (3000pcs/bag)

\*MT3411AT-N-EN chip mark is 411NY, and Y represents date code

## General Description

The MT3411-EN family is produced with BiCMOS technology. The Hall IC internally includes an on-chip Hall voltage generator, a voltage regulator for operation with supply voltage of 2.8V to 24V, temperature compensation circuitry, small-signal amplifier, Hall sensor with dynamic offset cancellation system, Schmitt trigger and an output drain with pull-up resistor. It also includes an clamp diode at output and reversed power supply protection enhances the robustness of Hall IC.

They are designed to respond to alternating North and South poles. While the magnetic flux density(B) is larger than operate point ( $B_{OP}$ ), the output will be turned on (Low), the output is held until the magnetic flux density(B) is lower than release point ( $B_{RP}$ ), then turn off (High).

The MT3411-EN family provides a variety of packages to customers: SOT-23 for surface mount and flat TO-92 for through-hole mount. All packages are RoHS compliant.

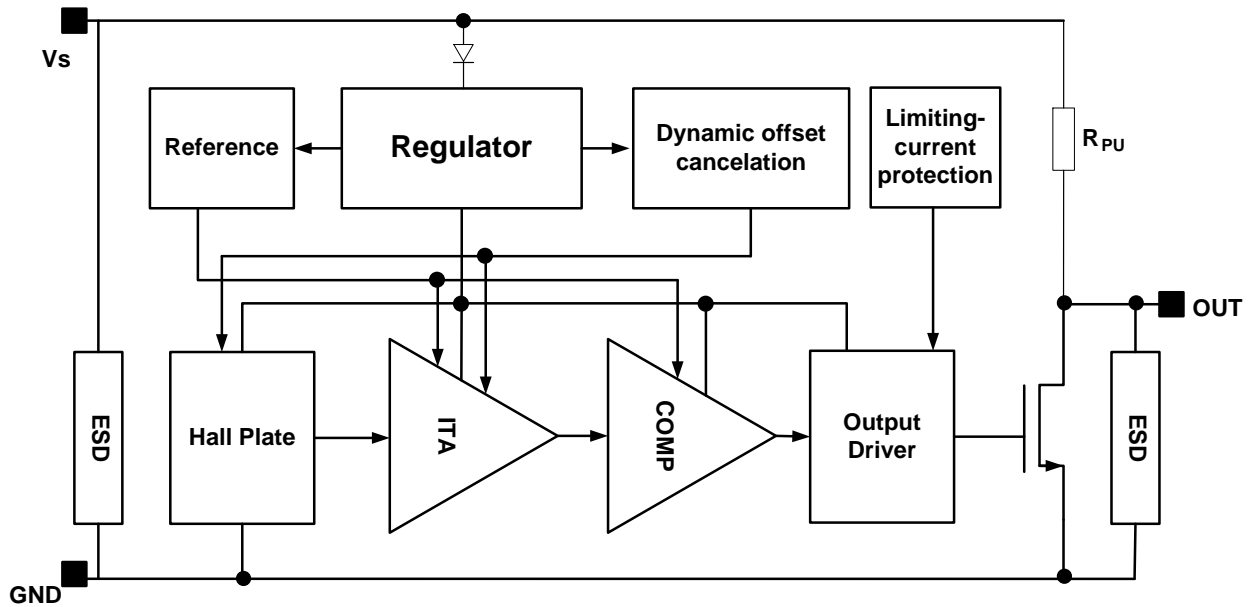

**Functional Block Diagram**

## Function Description

### Definition of Magnetic Parameters

$B_{OP}$ : Operating Point, Magnetic flux density applied on the branded side of the package which turns the output driver ON ( $V_{OUT}=Low$ )

$B_{RP}$ : Release Point, Magnetic flux density applied on the branded side of the package which turns the output driver OFF ( $V_{OUT}=High$ )

$B_{HYST}$ : Hysteresis Window,  $|B_{OP}-B_{RP}|$

### Definition of Switching Function

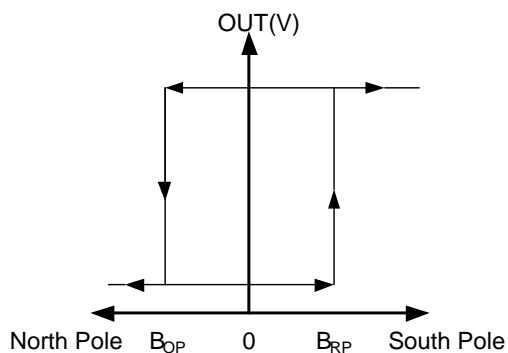

Switching Behavior of AT

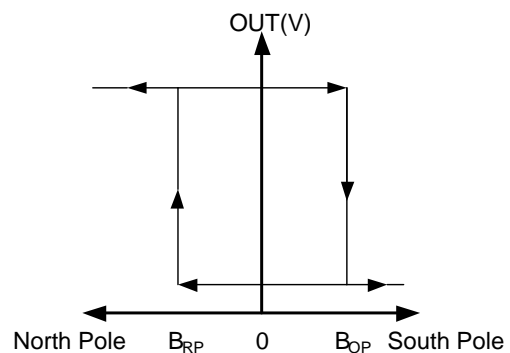

Switching Behavior of A and AT-N

# MT3411-EN Series



*BiCMOS, Latch, Hall-Effect Sensor With Pull-up Resistor*

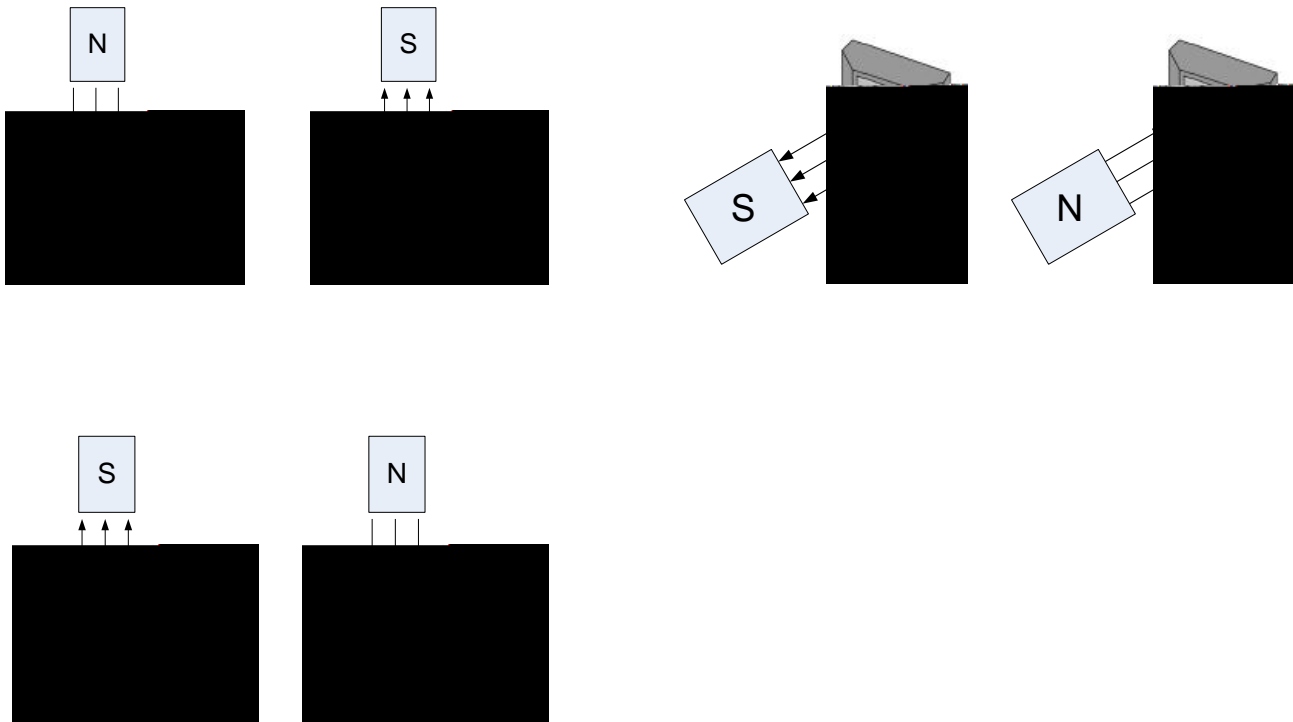

Note:

## Pin Description

MT3411AT-EN

Name	Number	Description
V <sub>s</sub>	1	Power
GND	3	Ground
OUT	2	Include pull-up resistor

MT3411A-EN (MT3411A-T-EN)

Name	Number	Description
V <sub>s</sub>	1	Power
GND	2	Ground
OUT		

MT3411AT-N-EN

## Electrical and Magnetic Characteristics

### Absolute Maximum Ratings

Absolute maximum ratings are limiting values to be applied individually, and beyond which the serviceability of the circuit may be impaired. Functional operability is not necessarily implied. Exposure to absolute maximum rating conditions for an extended period of time may affect device reliability.

Absolute maximum ratings: all voltages listed are referenced to GND.

Symbol	Parameters	Min	Max	Units
$V_S$	Supply Voltage	-	27	V
$V_{RCC}$	Reverse Battery Voltage	-27	-	V
$V_{OUT}$	Output Voltage	-	27	V
$I_{OUT}$	Continuous output current	-	27	mA
$T_A$	Operating ambient Temperature	-40	150	
$T_S$	Storage temperature	-50	150	
$T_J$	Junction Temperature	-	165	
B	Magnetic Flux	No Limit		Gauss

### Power derating Curve

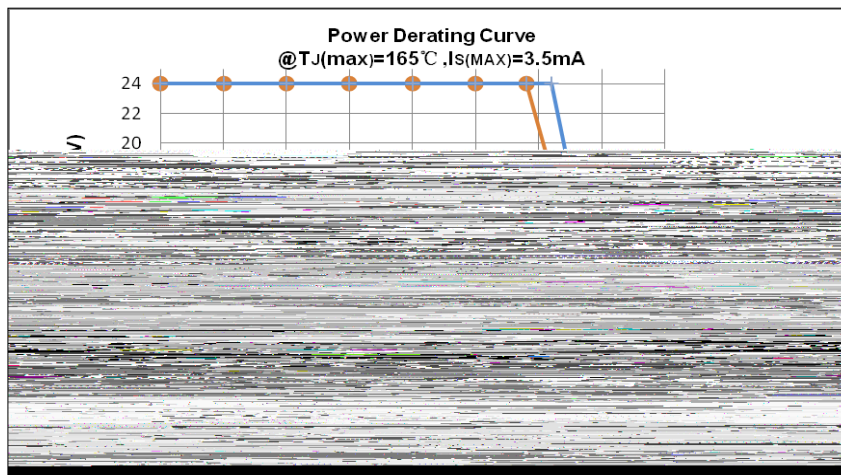

# MT3411-EN Series



BiCMOS, Latch, Hall-Effect Sensor With Pull-up Resistor

## MT3411-EN Series Specifications

At  $T_A = -40$  to  $150$  ,  $V_S = 2.8V$  to  $24V$  (unless otherwise specified)

Symbol	Parameter	Test Condition	Min	Typ	Max	Units
$V_S$	Supply Voltage	Operating	2.8	-	24	V
$I_S$	Supply Current	$B < B_{RP}$	1	2.3	3.5	mA
$I_{OCP}$	Short Circuit Protection Current	$B > B_{OP}$ , $V_{OUT} = V_S$		50		mA
$V_{DSON}$	Output Saturation Voltage	$I_{OUT} = 20mA$ , $B > B_{OP}$	-	-	0.4	V
$I_{OFF}$	Output Leakage Current	$V_{OUT} = 24V$	-	-	10	$\mu A$
$T_R^{1,2}$	Output Rise Time	$C_L = 20pF$	-	-	3.0	$\mu s$

## Characteristic Performance

Average Supply Current versus Supply Voltage

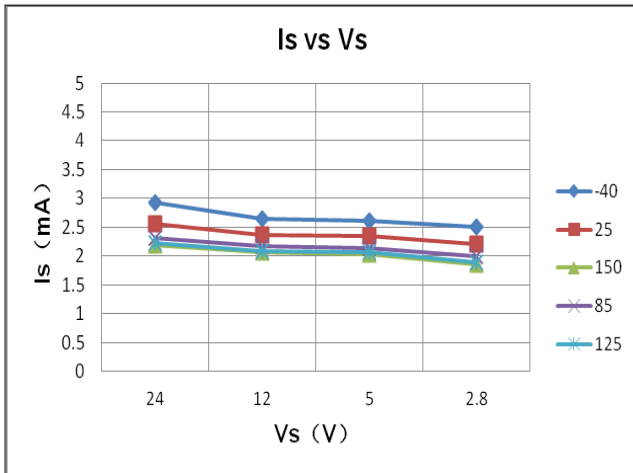

Average Supply Current versus Temperature

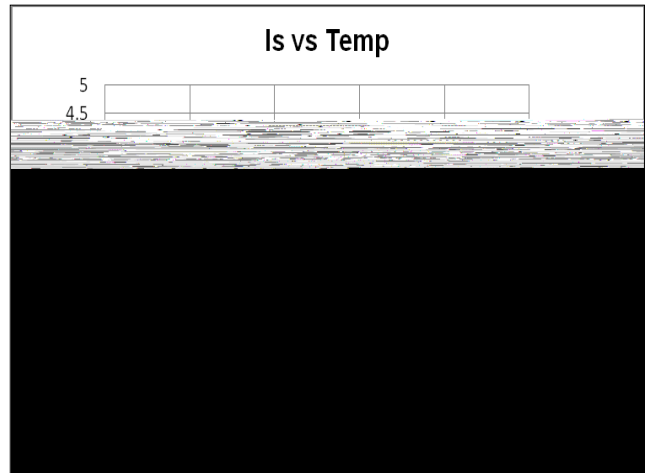

Magnetic Characteristics versus Supply Voltage

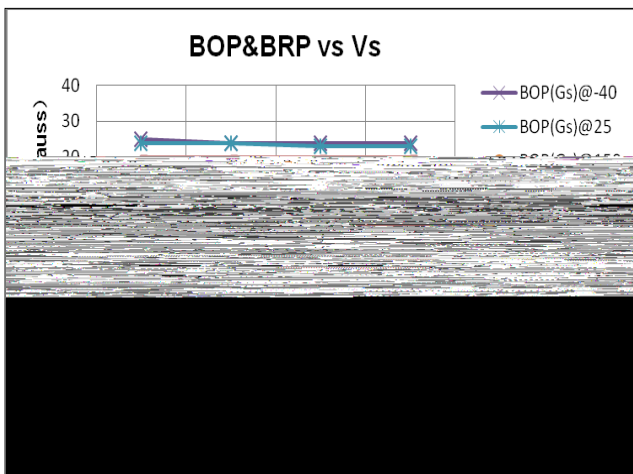

Magnetic Characteristics versus Temperature

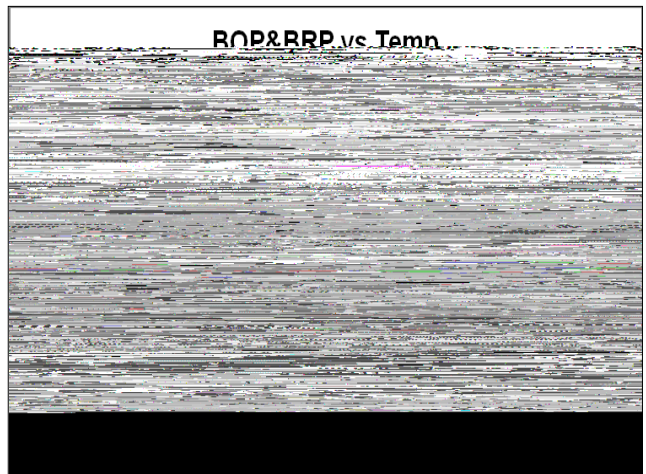

## Typical Application Circuit

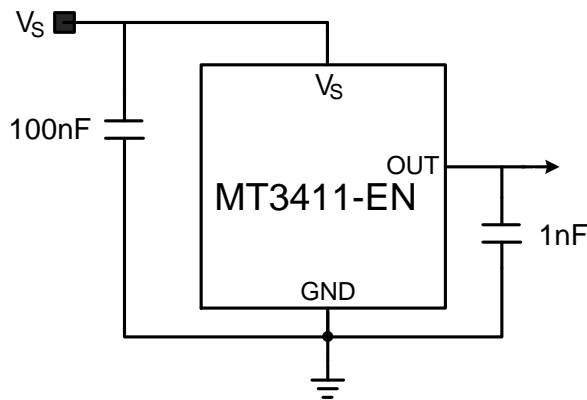

## Typical Output Waveform (The Flat TO-92 as an example)

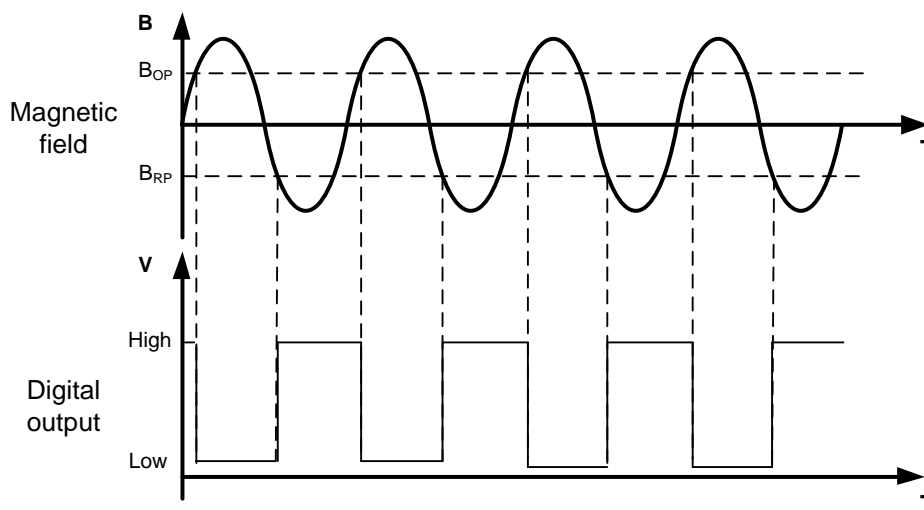

## Power On Output Waveform (The Flat TO-92 package as an example)

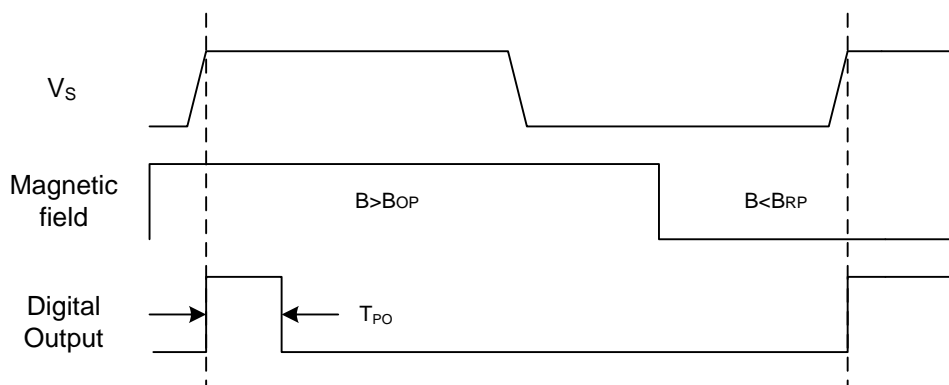

Note:  $V_S$  rise time  $< 1\mu s$ ,  $T_{PO}$  is the time from  $V_S$  becoming stable to output becoming valid.

# MT3411-EN Series



*BiCMOS, Latch, Hall-Effect Sensor With Pull-up Resistor*

## PACKAGE DESIGNATOR (MT3411A-EN) Flat TO-92

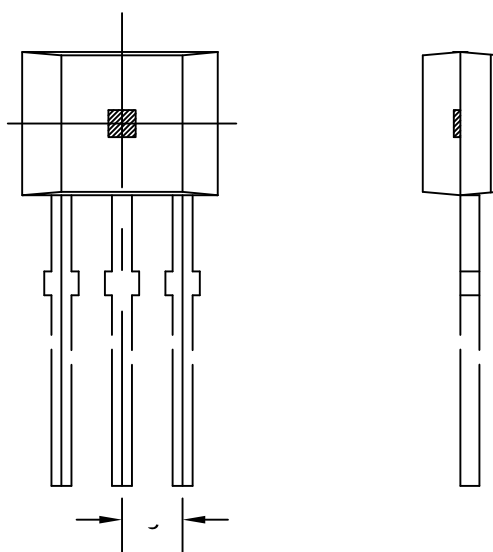
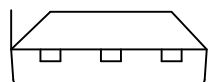

Symbol	Dimensions in Millimeters		Dimensions in Inches	
	Min	Max	Min	Max
A	1.420	1.670	0.056	0.066
A1	0.660	0.860	0.026	0.034
b	0.350	0.560	0.014	0.022
b1	0.400	0.550	0.016	0.022
C	0.360	0.510	0.014	0.020
D	3.900	4.200	0.154	0.165
D1	2.970	3.270	0.117	0.129
E	2.900	3.280	0.114	0.129
e	1.270 TYP		0.050 TYP	
e1	2.440	2.640	0.096	0.104
L	13.500	15.500	0.531	0.610
x	2.025TYP		0.080TYP	
y	1.545TYP		0.061TYP	
z	0.500TYP		0.020TYP	
	45°TYP		45°TYP	



**PACKAGE DESIGNATOR**  
(MT3411A-T-EN) Flat TO-92 Radial Lead

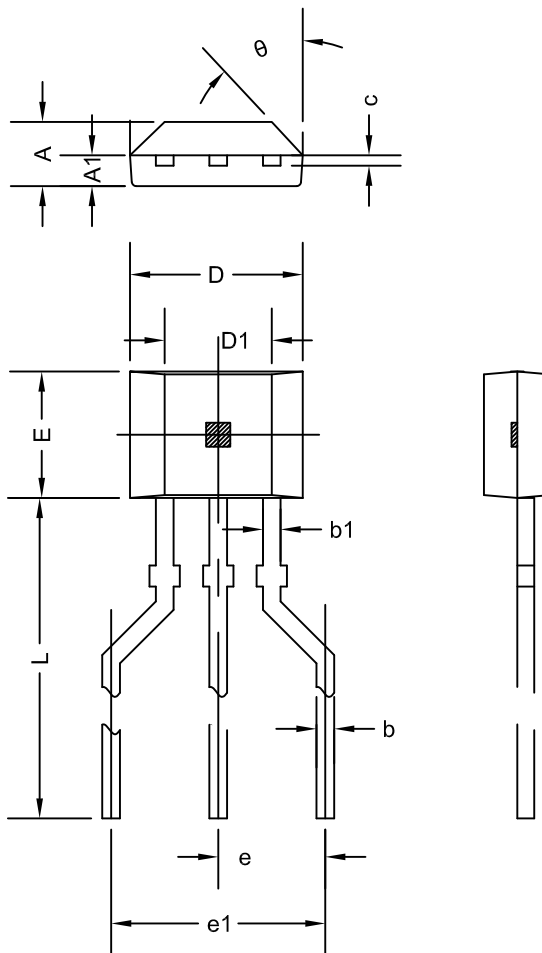

Symbol	Dimensions in Millimeters		Dimensions in Inches	
	Min	Max	Min	Max
A	1.420	1.670	0.056	0.066
A1	0.660	0.860	0.026	0.034
b	0.350	0.560	0.014	0.022
b1	0.400	0.550	0.016	0.022
c	0.360	0.510	0.014	0.020
D	3.900	4.200	0.154	0.165
D1	2.970	3.270	0.117	0.129
E	2.900	3.280	0.114	0.129
e	2.540TYP		0.100TYP	
e1	5.080TYP		0.200TYP	
L	14.300REF		0.563REF	
L1	2.150REF		0.085REF	
x	2.025TYP		0.080TYP	
y	1.545TYP		0.061TYP	
z	0.500TYP		0.020TYP	
	45°TYP		45°TYP	

# MT3411-EN Series

*BiCMOS, Latch, Hall-Effect Sensor With Pull-up Resistor*



**PACKAGE DESIGNATOR**  
MT3411AT-EN (MT3411AT-N-EN) SOT-23

Symbol	Dimensions in Millimeters		Dimensions in Inches	
	Min	Max	Min	Max
A	1.050	1.250	0.041	0.049
A1	0.000	0.100	0.000	0.004
A2	1.050	1.150	0.041	0.045
b	0.300	0.500	0.012	0.020
c	0.100	0.200	0.004	0.008
D	2.820	3.020	0.111	0.119
E	1.500	1.700	0.059	0.067
E1	2.650			